

3-7 Tiny Serial-to-Ethernet Device Server & Modbus Gateway

tDS-700 Series

Tiny Serial-to-Ethernet Device Server

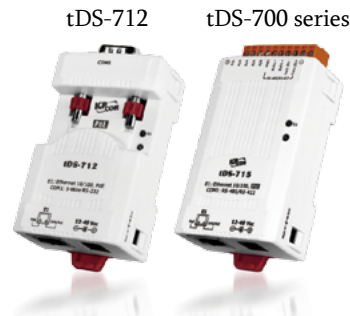
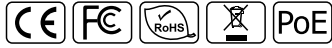

Features >>>

- Incorporates any RS-232/422/485 serial device in Ethernet
- VxComm Driver for 32/64-bit Windows XP/2003/Vista/7
- 10/100 Base-TX Ethernet, RJ-45 x1 (Auto-negotiating, auto MDI/MDIX, LED Indicators)
- Includes redundant power inputs: PoE and DC jack
- Allows easy firmware updates via the Ethernet
- Male DB-9 or terminal block connector for easy wiring
- RoHS Compliant & no Halogen
- Cost-effective Device Servers
- 32-bit MCU that efficiently handles network traffic
- Supports pair-connection (serial-bridge, serial-tunnel) applications
- Supports TCP, UDP, HTTP, DHCP, BOOTP and TFTP protocols
- Supports UDP responder for device discovery
- Allows automatic RS-485 direction control
- 2500 V_{DC} Isolation and +/-4 kV ESD protection for i versions
- Provides an intuitive web configuration interface
- Tiny form-factor and low power consumption

Introduction

The tDS-700 is a series of Serial-to-Ethernet device servers designed to add Ethernet and Internet connectivity to any RS-232 and RS-422/485 device, and to eliminate the cable length limitation of legacy serial communication. By using the VxComm Driver/Utility, the built-in COM port of the tDS-700 series can be virtualized to a standard PC COM port in Windows. Therefore, users can transparently access or monitor serial devices over the Internet/Ethernet without software modification.

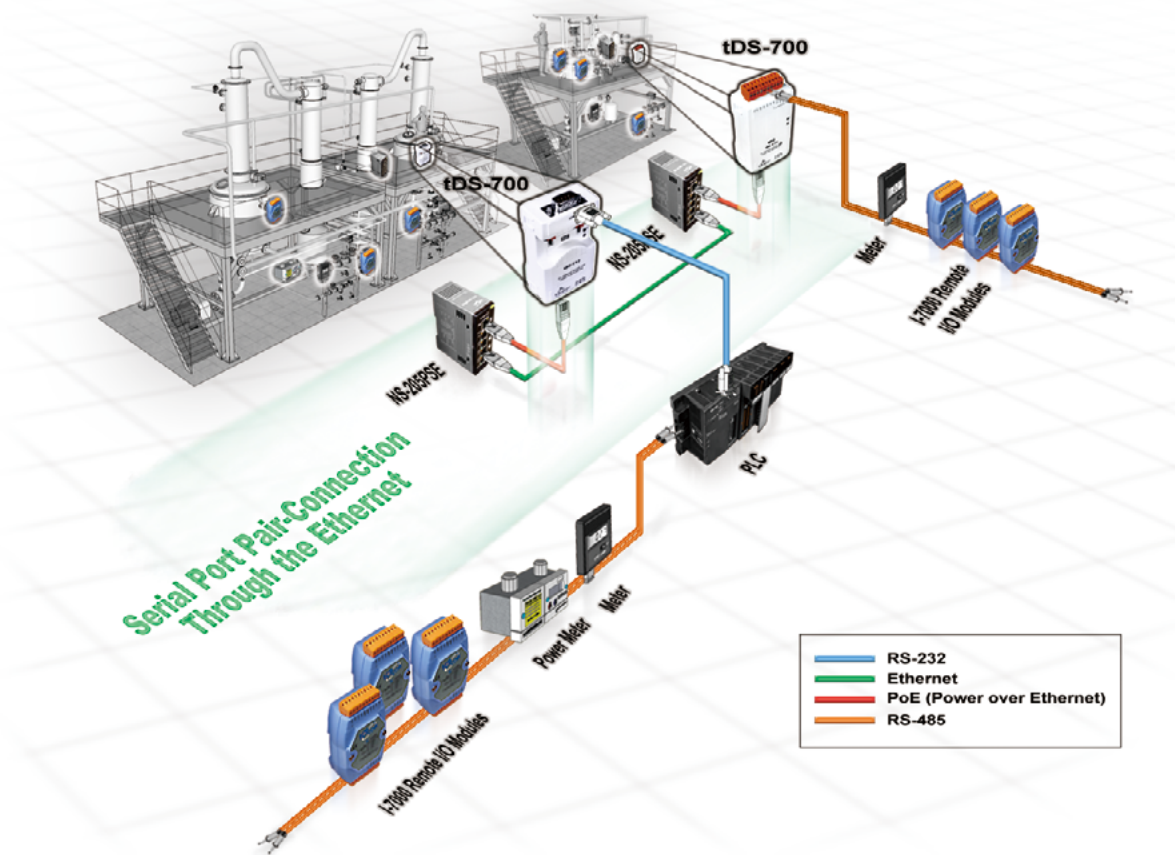

The VxComm Driver/Utility supports the most popular operating system in the world, including 32-bit and 64-bit Windows 7/Vista/2008/2003/XP. The virtual COM works transparently and is protocol independent, enabling perfect integration with your current central computer. The utility provides an easy configuration interface that can be used to quickly create and map virtual COM ports to one or several tDS-700 modules. In addition, the utility contains a built-in terminal program, so users can send/receive command/data via the terminal program for easy testing.

The tDS-700 device servers can be used to create a pair-connection application (as well as serial-bridge or serial-tunnel), and can then route data over TCP/IP between two serial devices, which is useful when connecting mainframe computers, servers or other serial devices that do not themselves have Ethernet capability. By virtue of its protocol independence and flexibility, the tDS-700 meets the demands of virtually any network-enabled application.

DHCP minimizes configuration errors caused by manual IP address configuration, such as address conflicts caused by the assignment of an IP address to more than one computer or device at the same time. The tDS-700 supports the DHCP client function, which allows the tDS-700 to easily obtain the necessary TCP/IP configuration information from a DHCP server. The tDS-700 also contains a UDP responder that transmits its IP address information in response to a UDP search from the VxComm Utility, making local management more efficient.

The tDS-700 features a powerful 32-bit MCU to enable efficient handling of network traffic. It also has a built-in web server that provides an intuitive web management interface to allow users to modify the settings of the module, including DHCP/Static IP, gateway/mask and serial ports.

Based on an amazing tiny form-factor, the tDS-700 achieves the maximum space savings that allows it to be easily installed anywhere, even directly attached to a serial device or embedded into a machine.



The tDS-700 series also contains a built-in CPU watchdog, which automatically resets the CPU if the built-in firmware is operating abnormally, or if there is no communication between the tDS-700 and the host for a predefined period of time (system timeout). This is an important feature that ensures the tDS-700 operates continuously, even in harsh environments. In addition, the tDS-700 series (for i version) also adds 2500 V_{DC} isolation and +/-4 kV ESD protection component that diverts the potentially damaging charge away from sensitive circuit to protect the module and equipment from the sudden and momentary electric current.

The tDS-700 offers true IEEE 802.3af-compliant (classification, Class 1) Power over Ethernet (PoE) functionality using a standard category 5 Ethernet cable to receive power from a PoE switch such as the NS-205PSE. If there is no PoE switch on site, the tDS-700 will also accept power input from a DC adapter. The tDS-700 is designed for ultra-low power consumption, reducing hidden costs from increasing fuel and electricity prices, especially when you have a huge amount of device servers installed. Reducing the amount of electricity consumed by choosing energy-efficient equipment can have a positive impact on maintaining a green environment.

The tDS-712 is equipped with a male DB-9 connector, while other models are equipped with a removable terminal block connector to allow easy wiring, and also supports automatic RS-485 direction control when sending and receiving data.

The tDS-700 has the same basic Serial-to-Ethernet gateway and virtual COM functions as the PPDS-700-MTCP series, as shown in the right-hand-side comparison table.

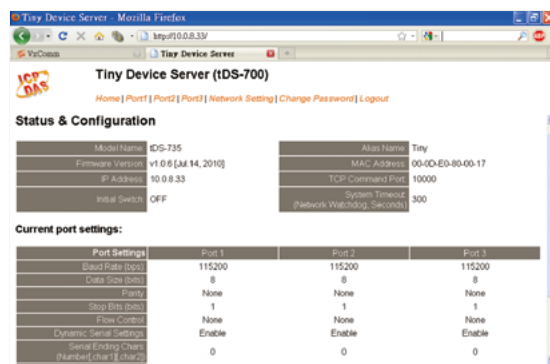
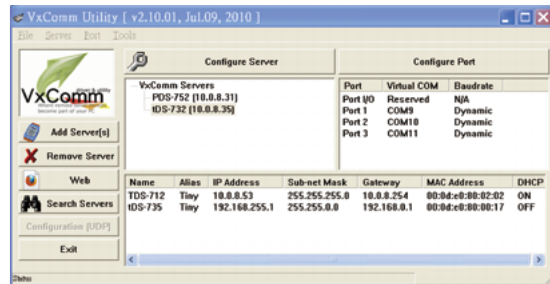

Comparison Table	tDS-700 Series	PPDS-700-MTCP Series
Ethernet	10/100 M, PoE	10/100 M, PoE
Programmable	-	Yes
Virtual COM	Yes	Yes
Virtual I/O	-	Yes
DHCP	Yes	Yes
Web Configuration	Yes	Yes
UDP Search	Yes	Yes
Modbus Gateway	-	Yes
Multi-client	-	Yes
Remarks	Cost-effective	-

Applications

- Factory Automation
- Building Automation
- Home Automation
- Remote Diagnosis and Management



1. Access serial device via Virtual COM ports

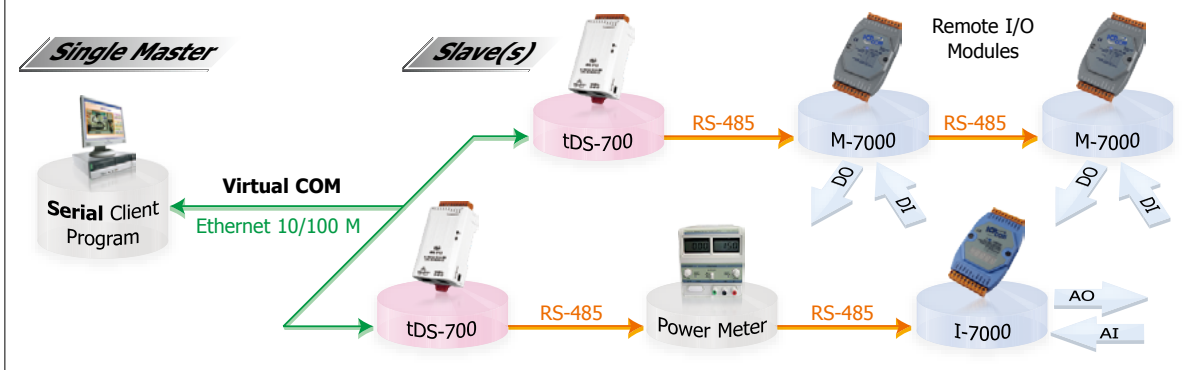

2. Access serial device via TCP/IP socket connection

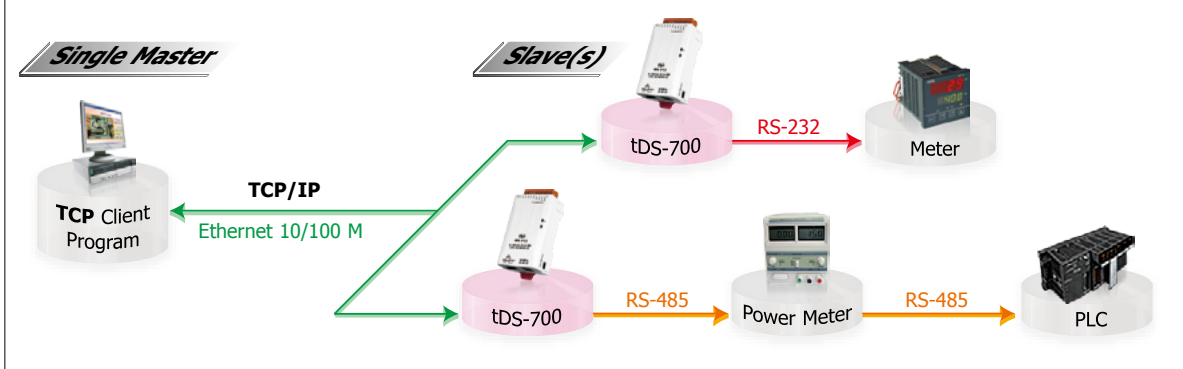

3. Serial converter application through pair-connection

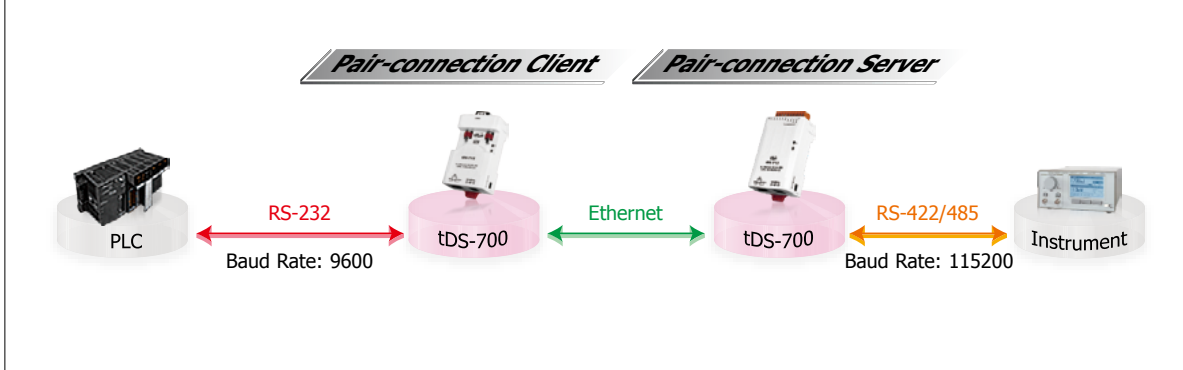

4. Virtual RS-485 bus application through pair-connection

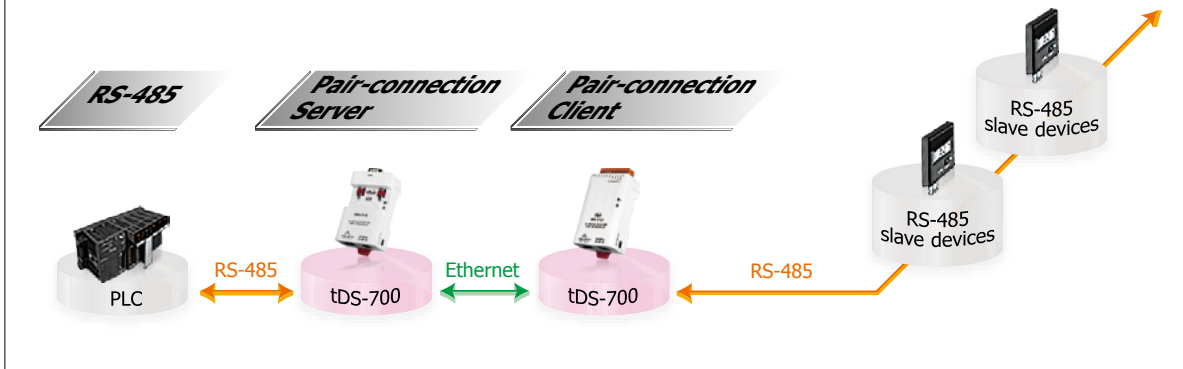

tGW-700 Series

Tiny Modbus/TCP to RTU/ASCII Gateway



tGW-712

tGW-700 series



Features ▶▶▶

- Incorporates any RS-232/422/485 serial device in Ethernet
- Supports Modbus TCP to RTU/ASCII Gateway
- Supports Modbus RTU/ASCII to TCP Gateway
- 10/100 Base-TX Ethernet, RJ-45 x1 (Auto-negotiating, auto MDI/MDIX, LED Indicators)
- Includes redundant power inputs: PoE and DC jack
- Allows easy firmware updates via the Ethernet
- Male DB-9 or terminal block connector for easy wiring
- RoHS Compliant & no Halogen
- Cost-effective Device Servers
- 32-bit MCU that efficiently handles network traffic
- Supports pair-connection (serial-bridge, serial-tunnel) applications
- Supports TCP, UDP, HTTP, DHCP, BOOTP and TFTP protocols
- Supports UDP responder for device discovery
- Allows automatic RS-485 direction control
- 2500 V_{DC} Isolation and +/-4 kV ESD protection for i versions
- Provides an intuitive web configuration interface
- Tiny form-factor and low power consumption

Introduction

Modbus has become a de facto standard industrial communication protocol, and is now the most commonly available means of connecting industrial electronic devices. Modbus allows for communication between many devices connected to the same RS-485 network, for example, a system that measures temperature and humidity and communicates the results to a computer. Modbus is often used to connect a supervisory computer with a remote terminal unit (RTU) in supervisory control and data acquisition (SCADA) systems.

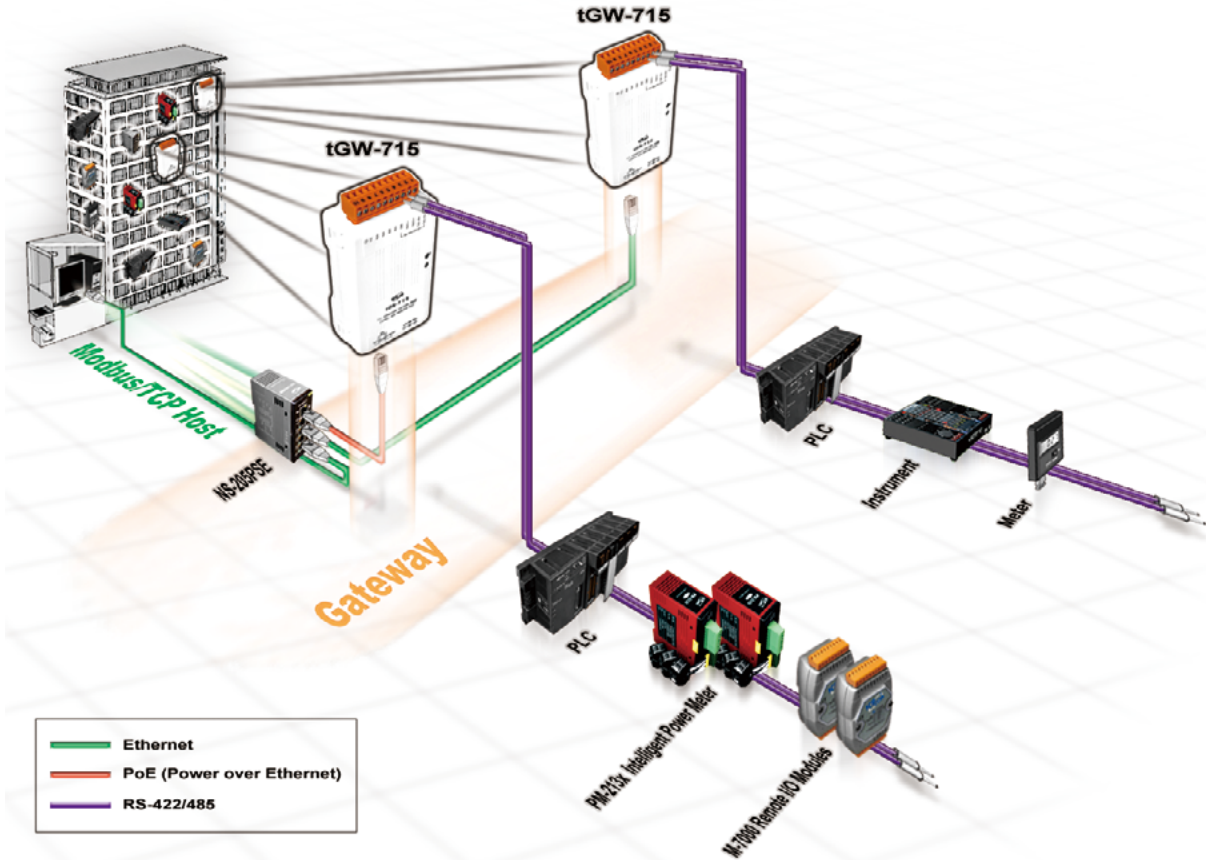

3
7
Serial Device Server

The tGW-700 module is a Modbus TCP to RTU/ASCII gateway that enables a Modbus/TCP host to communicate with serial Modbus RTU/ASCII devices through an Ethernet network, and eliminates the cable length limitation of legacy serial communication devices. The module can be used to create a pair-connection application (as well as serial-bridge or serial-tunnel application), and can then route data over TCP/IP between two serial Modbus RTU/ASCII devices, which is useful when connecting mainframe computers, servers or other serial devices that use Modbus RTU/ASCII protocols and do not themselves have Ethernet capability.

DHCP minimizes configuration errors caused by manual IP address configuration, such as address conflicts caused by the assignment of an IP address to more than one computer or device at the same time. The tGW-700 module supports the DHCP client function, which allows it to easily obtain the necessary TCP/IP configuration information from a DHCP server. The module also contains a UDP responder that transmits its IP address information in response to a UDP search from the eSearch utility, making local management more efficient.

The tGW-700 module features a powerful 32-bit MCU to enable efficient handling of network traffic, and also has a built-in web server that provides an intuitive web management interface that allows users to modify the configuration of the module, including the DHCP/Static IP, the gateway/mask settings and the serial port settings.

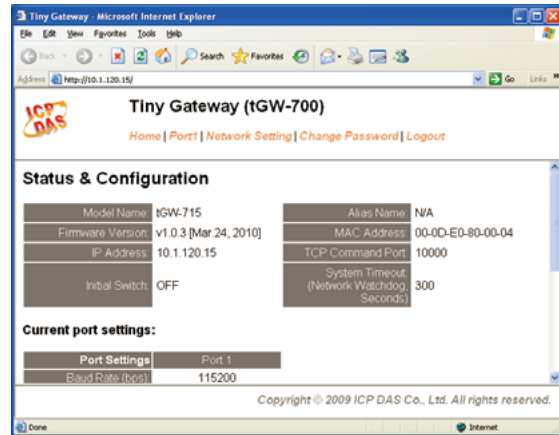

The module contains a dual watchdog, including a CPU watchdog (for hardware functions) and a host watchdog (for software functions). The CPU watchdog automatically resets the CPU if the built-in firmware is operating abnormally, while the host watchdog automatically resets the CPU if there is no communication between the module and the host (PC or PLC) for a predefined period of time (system timeout). The dual watchdog is an important feature that ensures the module operates continuously, even in harsh environments.



The tGW-700 module offers true IEEE 802.3af-compliant (classification, Class 1) Power over Ethernet (PoE) functionality using a standard category 5 Ethernet cable to receive power from a PoE switch such as the NS-205PSE. If there is no PoE switch on site, the module will also accept power input from a DC adapter. The tGW-700 module is designed for ultra-low power consumption, reducing hidden costs from increasing fuel and electricity prices, especially when you have a large number of modules installed. Reducing the amount of electricity consumed by choosing energyefficient equipment can have a positive impact on maintaining a green environment. In addition, the tGW-700 series (for i version) also adds

2500 V_{DC} isolation and +/-4 kV ESD protection component that diverts the potentially damaging charge away from sensitive circuit to protects the module and equipment from the sudden and momentary electric current.

The module is equipped with a male DB-9 or a removable terminal block connector to allow easy wiring. Based on an amazing tiny form-factor, the tGW-700 achieves maximum space savings that allows it to be easily installed anywhere, even directly embedded into a machine. It also supports automatic RS-485 direction control when sending and receiving data, thereby improving the stability of the RS-485 communication.

Comparison Table	Ethernet	Programmable	Virtual COM	Virtual I/O	DHCP	Web Configuration	UDP Search	Modbus Gateway	Multi-client
tGW-700 Series	10/100 M, PoE	-	-	-	Yes	Yes	Yes	Yes	-
PPDS-700-MTCP Series	10/100 M, PoE	Yes	Yes	Yes	Yes	Yes	Yes	Yes	Yes

Applications

- Factory Automation
- Home Automation
- Building Automation
- Remote Diagnosis and Management

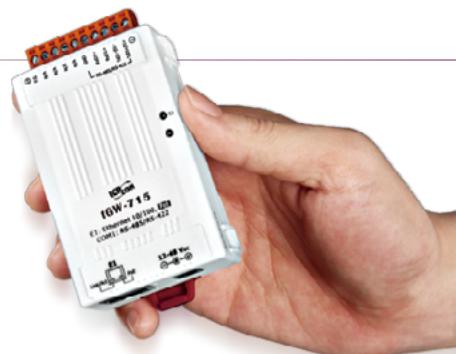

1. Modbus TCP to RTU/ASCII Gateway application

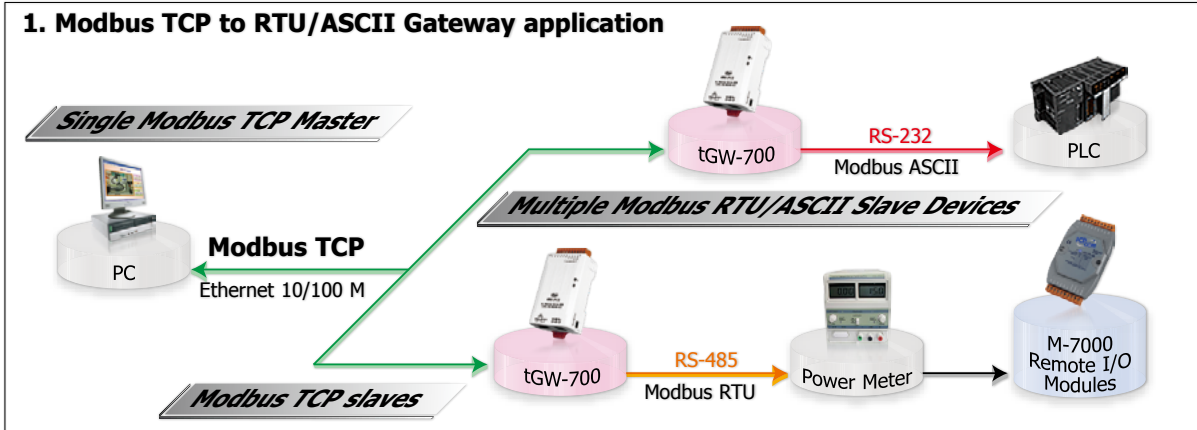

2. Modbus TCP to RTU/ASCII Gateway application (dual-port)

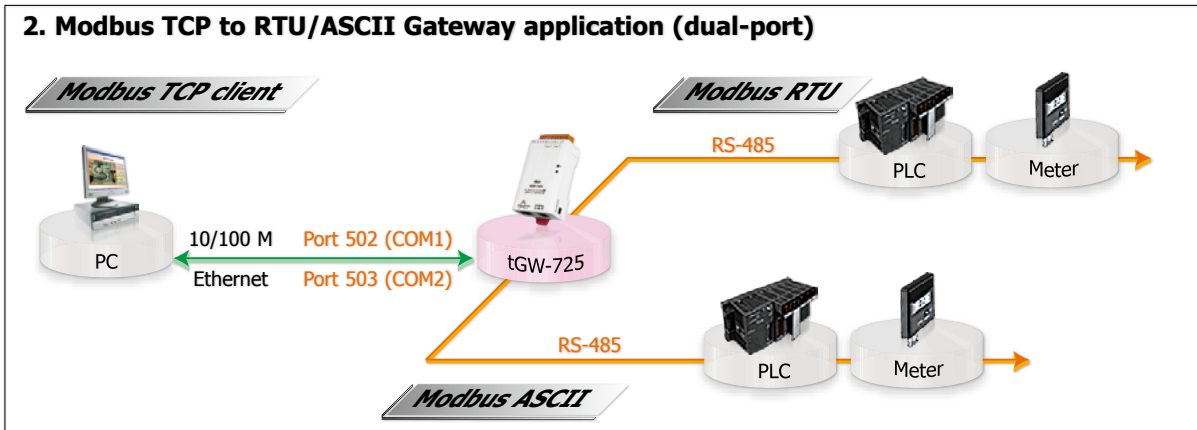

3. Modbus RTU/ASCII to TCP Gateway application (like pair-connection)

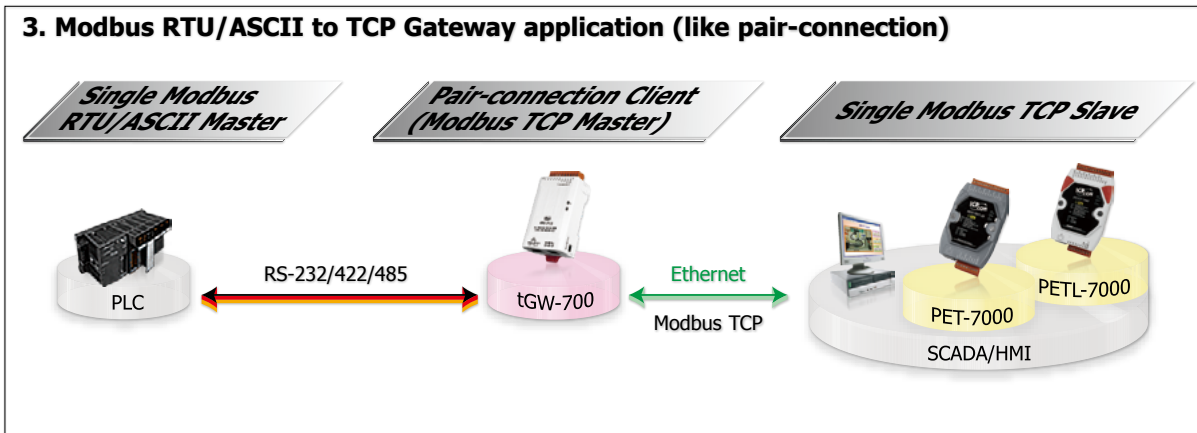

4. Virtual RS-485 bus application through pair-connection

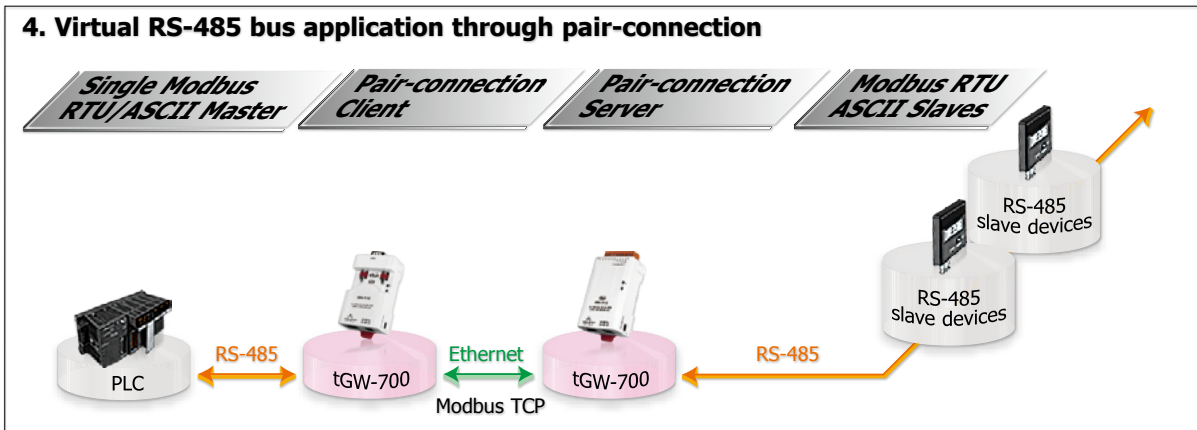

System Specifications

Models	tDS-712 tGW-712	tDS-722 tGW-722	tDS-732 tGW-732	tDS-715 tGW-715	tDS-715i tGW-715i	tDS-725 tGW-725	tDS-735 tGW-735	tDS-718 tGW-718	tDS-724 tGW-724	tDS-734 tGW-734
System										
CPU	32-bit MCU									
Communication Interface										
Ethernet	10/100 Base-TX, 8-pin RJ-45 x 1, (Auto-negotiating, Auto-MDI/MDIX, LED indicator) PoE (IEEE 802.3af, Class 1)									
COM1	5-wire RS-232	5-wire RS-232	3-wire RS-232	2-wire RS-485 4-wire RS-422		2-wire RS-485	2-wire RS-485	3-wire RS-232 2-wire RS-485 4-wire RS-422	2-wire RS-485	2-wire RS-485
COM2	-	5-wire RS-232	3-wire RS-232	-		2-wire RS-485	2-wire RS-485	-	5-wire RS-232	3-wire RS-232
COM3	-	-	3-wire RS-232	-		-	2-wire RS-485	-	-	3-wire RS-232
Self-Tuner	-			Yes, automatic RS-485 direction control						
UART	16C550 or compatible									
Isolation	-	-	-	-	2500 V _{DC}	-	-	-	-	-
ESD Protection	-	-	-	-	+/-4 kV	-	-	-	-	-
COM Port Format										
Baud Rate	115200 bps Max.									
Data Bit	5, 6, 7, 8									
Parity	None, Odd, Even, Mark, Space									
Stop Bit	1, 2									
Power										
Power Input	PoE	IEEE 802.3af, Class 1								
	DC Jack	+12 ~ 48 V _{DC}								
Power Consumption	0.07 A @ 24 V _{DC}									
Connector	Male DB-9 x 1		10-Pin Removable Terminal Block x 1							
Mechanical										
Flammability	Fire-Retardant Materials (UL94-V0 Level)									
Dimensions (W x H x D)	52 mm x 90 mm x 27 mm		52 mm x 95 mm x 27 mm							
Installation	DIN-Rail mounting									
Environment										
Operating Temperature	-25 °C ~ +75 °C									
Storage Temperature	-30 °C ~ +80 °C									
Humidity	10 ~ 90% RH, non-condensing									
3-wire RS-232: RxD, TxD, GND (Non-isolated) 5-wire RS-232: RxD, TxD, CTS, RTS, GND (Non-isolated) 2-wire RS-485: DATA+, DATA-, GND (Non-isolated) 4-wire RS-422: TxD+, TxD-, RxD+, RxD-, GND (Non-isolated)										

Pin Assignments

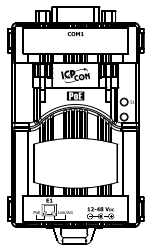

tDS-712/tGW-712		
09	N/A	
08	CTS1	
07	RTS1	
06	N/A	
05	GND	
04	N/A	
03	TxD1	
02	RxD1	
01	N/A	

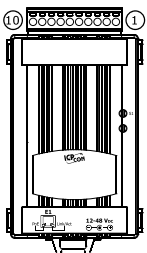

tDS-715i/tGW-715i		
10	F.G.	
09	N/A	
08	N/A	
07	N/A	
06	N/A	
05	ISO.GND	
04	RxD1-	
03	RxD1+	
02	TxD1-/D1-	
01	TxD1+/D1+	

tDS-722/tGW-722		
10	F.G.	
09	CTS2	
08	RTS2	
07	RxD2	
06	TxD2	
05	GND	
04	CTS1	
03	RTS1	
02	RxD1	
01	TxD1	

tDS-732/tGW-732		
10	F.G.	
09	GND	
08	RxD3	
07	TxD3	
06	GND	
05	RxD2	
04	TxD2	
03	GND	
02	RxD1	
01	TxD1	

tDS-735/tGW-735		
10	F.G.	
09	GND	
08	D3-	
07	D3+	
06	GND	
05	D2-	
04	D2+	
03	GND	
02	D1-	
01	D1+	

tDS-718/tGW-718		
10	F.G.	
09	N/A	
08	GND	
07	RxD1	
06	TxD1	
05	GND	
04	RxD1-	
03	RxD1+	
02	TxD1-/D1-	
01	TxD1+/D1+	

tDS-715/tGW-715		
10	F.G.	
09	N/A	
08	N/A	
07	N/A	
06	N/A	
05	GND	
04	RxD1-	
03	RxD1+	
02	TxD1-/D1-	
01	TxD1+/D1+	

tDS-725/tGW-725		
10	F.G.	
09	N/A	
08	N/A	
07	N/A	
06	GND	
05	D2-	
04	D2+	
03	GND	
02	D1-	
01	D1+	

tDS-724/tGW-724		
10	F.G.	
09	N/A	
08	CTS2	
07	RTS2	
06	GND	
05	RxD2	
04	TxD2	
03	GND	
02	D1-	
01	D1+	

tDS-734/tGW-734		
10	F.G.	
09	GND	
08	RxD3	
07	TxD3	
06	GND	
05	RxD2	
04	TxD2	
03	GND	
02	D1-	
01	D1+	

Dimensions (Unit: mm)

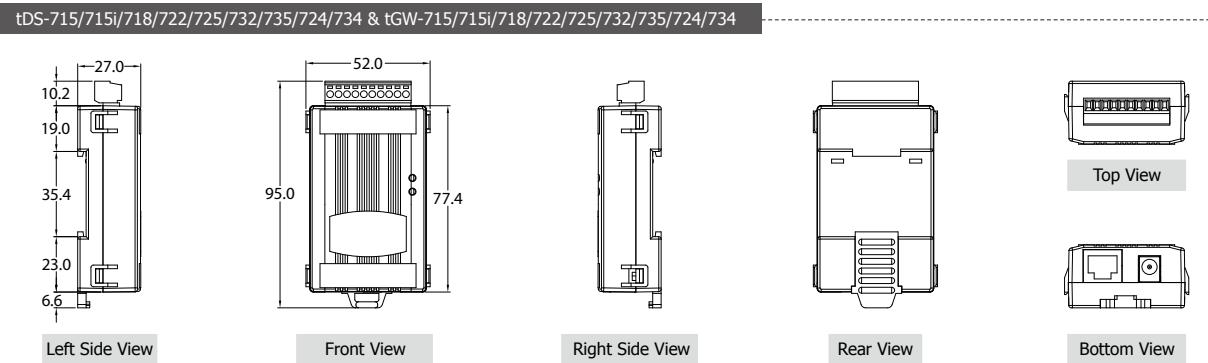
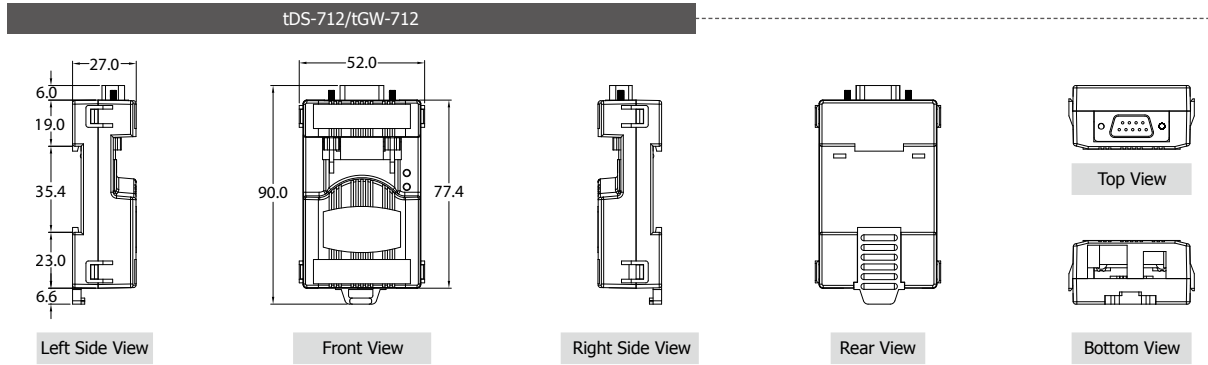

Ordering Information

tDS-700 Series	
tDS-712 CR	Tiny Device Server with PoE and 1 RS-232 Port (RoHS)
tDS-722 CR	Tiny Device Server with PoE and 2 RS-232 Ports (RoHS)
tDS-732 CR	Tiny Device Server with PoE and 3 RS-232 Ports (RoHS)
tDS-715 CR	Tiny Device Server with PoE and 1 RS-422/485 Port (RoHS)
tDS-715i CR Available soon	Tiny Device Server with PoE and 1 Isolated RS-422/485 Port (RoHS)
tDS-725 CR	Tiny Device Server with PoE and 2 RS-485 Ports (RoHS)
tDS-735 CR	Tiny Device Server with PoE and 3 RS-485 Ports (RoHS)
tDS-718 CR	Tiny Device Server with PoE and 1 RS-232/422/485 Port (RoHS)
tDS-724 CR	Tiny Device Server with PoE, 1 RS-485 and 1 RS-232 Ports (RoHS)
tDS-734 CR	Tiny Device Server with PoE, 1 RS-485 and 2 RS-232 Ports (RoHS)
Includes: One CA-002 cable.	
tGW-700 Series	
tGW-712 CR	Tiny Modbus/TCP to RTU/ASCII Gateway with PoE and 1 RS-232 Port (RoHS)
tGW-722 CR	Tiny Modbus/TCP to RTU/ASCII Gateway with PoE and 2 RS-232 Ports (RoHS)
tGW-732 CR	Tiny Modbus/TCP to RTU/ASCII Gateway with PoE and 3 RS-232 Ports (RoHS)
tGW-715 CR	Tiny Modbus/TCP to RTU/ASCII Gateway with PoE and 1 RS-422/485 (RoHS)
tGW-715i CR Available soon	Tiny Modbus/TCP to RTU/ASCII Gateway with PoE and 1 Isolated RS-422/485 (RoHS)
tGW-725 CR	Tiny Modbus/TCP to RTU/ASCII Gateway with PoE and 2 RS-485 Ports (RoHS)
tGW-735 CR	Tiny Modbus/TCP to RTU/ASCII Gateway with PoE and 3 RS-485 Ports (RoHS)
tGW-718 CR	Tiny Modbus/TCP to RTU/ASCII Gateway with PoE and 1 RS-232/422/485 Port (RoHS)
tGW-724 CR	Tiny Modbus/TCP to RTU/ASCII Gateway with PoE, 1 RS-485 and 1 RS-232 Ports (RoHS)
tGW-734 CR	Tiny Modbus/TCP to RTU/ASCII Gateway with PoE, 1 RS-485 and 2 RS-232 Ports (RoHS)
Includes: One CA-002 cable.	

Accessories

CA-002	DC connector to 2-wire power cable, 0.3 M
CA-0915	Male DB-9 to Female DB-9 Cable, 1.5 m
CA-0910F	Female DB-9 to Female DB-9 Cable, 1.0 m
CA-0910N	DB-9 Female-Female 3-wire Null Modem Cable, 1M
CA-PC09F	DB-9 Female Connector with Plastic Cover
FRA05-S12-SU CR	12V/0.58A (max.) Power Supply (RoHS, for tDS/tGW-700)
DIN-KA52F CR	24V/1.04A, 25 W Power Supply with DIN-Rail Mounting (RoHS, for NS-205 and NS-205PSE-24V)
DIN-KA52F-48 CR	48V/0.52A, 25 W Power Supply with DIN-Rail Mounting (RoHS, for NS-205PSE)
NS-205 CR	Unmanaged 5-port Industrial Ethernet Switch (RoHS)
NS-205PSE CR	Unmanaged Ethernet Switch with 4 PoE Ports and 1 RJ-45 Uplink (RoHS)
NS-205PSE-24V CR	Unmanaged 5-port 10/100 Mbps PoE (PSE) Ethernet Switch; 24 Vdc Input (RoHS)